

Integrating EMI Filters and Appliance Motor Controls

**Mr. Carl J. Dister
LCR Electronics, Inc.
9 South Forest Avenue
Norristown, PA 19401
U.S.A.**

**Telephone: 1-800-527-4362
Fax: (610) 278-0935
Email: cdister@lcr-inc.com
WEB Site: www.lcr-inc.com**

ABSTRACT

Although appliances for the domestic market do not generally require an EMI filter, this will be changing with the advent of Smart Appliances. Integrating this EMI filter and the appliance motor control onto the same printed circuit board can save considerable cost. Such integration however requires expertise in the design of both EMI filters and controllers to avoid unwanted interactions as the two circuits are brought in close proximity. This paper describes some popular types of appliance motor controls, their associated sources of EMI, the process of integrating the EMI filter and motor control, and cost savings by this integration.

OVERVIEW OF APPLIANCE MOTORS AND CONTROLS

There are over 25 classifications of electric motors¹. For each motor there are several controllers that can be utilized in applications requiring on/off control to complex speed/torque control, depending on the cost and performance needed¹¹. Table 1 is a subset of these motor and control types typically found in the appliance industry. Two of these motor controls will be explained in more detail.

Overview of a Typical Triac-Based Universal Motor Control

Although there are several motor technologies being introduced to the Appliance industry, the Universal Motor is still the predominant motor at the present time for applications below 1HP and requiring high speed. Although it has lower life than its brushless counterparts, Universal motors are well suited for low duty cycle applications where motor efficiency is not as critical.

The control of a universal motor is typically performed with a low cost Triac². A simple universal motor control can be found in Figure 1. For cost sensitive applications, an un-isolated, zener diode (ZD1) based power supply is used. Line synchronization and triac gate control are performed with a microcontroller.

In this control, the microcontroller turns on the triac at the appropriate point in the line cycle, allowing the appropriate voltage to be applied to the motor for the desired speed and torque

The largest source of EMI noise with this type of control is the switching of the triac. Typically, the EMI noise level generated is high in the low frequency conducted range from 150KHz to 1MHz.

When designing this type of control, there are tradeoffs between optimum control strategy and lowest level of EMI. For example, it may be beneficial to switch the triac only at zero crossings of the input power to keep EMI noise low. But this would greatly compromise the speed control. Some method of skip firing would need to be

employed to vary the voltage, resulting in poor control. *In general, designing an optimum motor control is contrary to designing for the lowest EMI.*

Overview of a Typical IGBT-Based Brushless Motor Control

In applications requiring lower speed, higher performance, or elimination of brushes, Induction and PM Brushless Motors are used.

The control of these motors³ typically uses IGBT's as shown in Figure 2. A diode rectifier and electrolytic capacitor are used to convert the AC line to DC, which is then switched to the motor windings by the IGBT's.

In this type of control, gate drivers are needed to fire the IGBT's connected to high voltage. Also, bus current and voltage sensing is usually required. Caution is needed in connecting grounds to keep isolation, and reduce signal noise.

Considering EMI in this control is much different than in the triac controller. The input current is switched through the front end bridge rectifier, creating high current peaks. The IGBT's are switched in the 2KHz to 20KHz range, causing large, fast voltage transients into the motor windings⁸. The EMI is no longer focused down at low frequency conducted, but now extends into the radiated range. As seen before, tradeoffs need to be made between performance and EMI. For example, switching the IGBT's at lower frequencies would reduce EMI. However, this causes slower current

control, attributing to poorer speed regulation and higher acoustic noise. Once again, designing the optimum control is contrary to designing for minimum EMI emissions.

Other Motor Controls

There are several other motor controls ranging in complexity between the "one switch" solution of the triac control and the "six switch" solution of the IGBT control. Each depends on motor type and desired performance. The switches can vary between triacs, SCR's, IGBT's and MOSFETS. In most of these permutations of controllers, experience shows that in each case, the reoccurring theme of trading off between performance and EMI levels exists.

OVERVIEW OF TYPICAL EMI FILTER

Figures 1 and 2 contain several sources of electromagnetic noise, which will be discussed later. To suppress the noise generated by these sources, an EMI filter is typically employed. Figure 3 illustrates a typical EMI filter used for appliances⁴.

Traditionally, this type of circuit is added to an appliance when it is targeted for export. This is done in order to live up to the standards imposed outside the U.S. (e.g. EN55014-1).

This can increase the system cost significantly. In an attempt to reduce the system cost, it is desirable to merge the EMI filter and the motor control onto a common printed circuit

card. During the process of integration, careful selection of components (with a focus on EMI) and proper routing of the board can reduce costs.

To design these filters, and achieve these cost reductions, it is important to understand some of the sources and methods of reducing EMI⁸.

CONDUCTED/RADIATED EMISSIONS OF MOTOR AND CONTROL

The system found in Figure 1 has several sources of EMI⁷. The components themselves are the sources of EMI, and the methods of propagation are in the wires and pc board traces connecting them. The sources include:

- Motor Brush Arc
- Triac Switching
- Diode Commutation
- Microcontroller Oscillator

These sources become transmitters of electromagnetic noise when the wires and connections between components act as antennas⁴. Electromagnetic noise transmitted into the air is known as Radiated Emissions (above 30MHZ), and electromagnetic noise transmitted into the power cord is known as Conducted Emissions (below 30MHZ.)

During the design process, if these sources of EMI and their transmission paths are considered, several actions can be made to reduce overall system cost⁵. Below is a list of actions that can be taken during

development to reduce these sources and transmission paths:

- Printed Circuit Board Layout
 - Keep noisy components together and in the center away from the edges
 - Use ground planes
 - Keep traces short as possible
 - Avoid loops in the traces
 - Use de-coupling capacitors
 - Round the corners of traces carrying high frequency
 - Consider Snubber design for Triac
 - Use Low EMI microcontrollers
- Wire Routings
 - Keep unfiltered wires away from filtered wires
 - Keep wires short
 - Use twisted pairs when possible
 - Keep wires away from brushes and other sources of EMI

INTEGRATED FILTER AND CONTROL

After considering the sources and methods of reducing EMI, the comparison between the separate and integrated systems should be clearer.

The total size of the PC Board is less than the area of both. Several factors contribute to this. Most importantly, there is no need for interconnection between the filter and the control, since the board itself makes these connections. (Note: this also

eliminates wire connections, which add to EMI by acting as antennas.)

From a component viewpoint, there will be a slight increase in cost to upgrade passive components for reduced EMI (e.g snubbers) which is more than offset by the decreasing cost of filter components. As a result overall costs come down.

SMART APPLIANCES AND EMI

Smart Appliances in order to be smart need to be capable of performing, at a minimum, the following three things. First, they must communicate to the outside world over some medium. Second, they must have information worthy of communicating. Third, they may not interfere with other Smart Appliances in proximity.

Smart Appliance Communication

Adding communications to an appliance causes EMI. Consider the operating frequency ranges of the following smart appliance communications protocols:

- Power Line Communication– X10: In the X10 protocol, communications take place over the power line. A 120KHz carrier is superimposed over the 60Hz power line¹².
- Wireless Communication – Bluetooth: The Bluetooth protocol uses a high frequency carrier¹³ at 2.4GHz

- Wired Communication – Ethernet/Category 5: Typical frequencies for Ethernet communications¹⁴ are 10MHz and 100MHZ
- Wired Communications – CEBus: This protocol spreads the frequency spectrum from 100KHZ to 400KHZ

Each of these protocols has frequencies that must be factored into the design of appropriate EMI filters. The filter prevents electromagnetic energy from leaving an appliance. It filters out the ‘bad’ frequencies. For example, if the appliance is sealed up to limit radiated emissions, wireless communications may be difficult. If a filter is in the unit to limit conducted emissions, power line communications may be difficult.

Smart Appliance Diagnostics

Consider the information transmitted over these communications protocols. Some of this information includes:

- New software to allow appliances to be upgraded
- Information about the operation of the unit (running time, recipes used...)
- How much energy has been consumed by the appliance
- Diagnostic Information

Of this list, diagnostics poses a serious EMI problem¹⁵. In appliances with a motor control, much of the information used to determine part failure is contained in the same electromagnetic spectrum as communication protocols and EMI filters. Sorting out these frequencies is precise business.

Figure 4 demonstrates the overlap of EMI filters, diagnostics information, and communications protocols that will be critical to sort out and manage in future Smart Appliance motor controls.

The Chaos Factor

The Chaos Factor describes the condition when two or more appliances are brought into proximity with one another. Careful planning must be made to insure that no malfunctions in the Smart Appliances occur as they communicate with each other and try and perform self-diagnostics.

For example, a failing motor in one appliance could cause noise on the power line that is interpreted as a failure in another appliance. This cross-contamination could lead to hazardous safety conditions. Consider a Smart Appliance transmitting a pending failure through the air at high frequencies. This high frequency EMI could cause a safety device (e.g. carbon monoxide detector, fire alarm,...) to stop working.

COST SAVINGS

By integrating the filter and motor control, a considerable material savings is realized. Although it is clear that this integration results in material cost reductions, there are several other additional savings:

Development Time – Overall appliance development costs can be substantially reduced by considering EMI in the first stages of the project.

Manufacturing – As mentioned earlier, the interconnection and test time for installing two separate assemblies is reduced considerably.

Reliability / MTBF – Because of the fewer components, wiring, and interconnects, the reliability / MTBF of the system is higher with the integrated filter and control. Therefore, the product should last longer, seeing fewer returns from the field.

CONCLUSION

There is clearly a savings in integrating the EMI filter and Motor Control of an Appliance into one printed circuit board. This should be done early in the design to avoid increased product costs, and increased overall development costs. Each year, the number of new developments in EMI reduction in motor controls continues to grow^{9 10}.

Although the use of EMI filters have been restricted to the export Appliance market, the advent of Smart Appliances may force domestic products into needing the filters as well. Future appliance designs, even DOMESTIC ONLY, should consider leaving room for an EMI filter on the control board.

Smart Appliances will need EMI filters for at least three reasons:

Communications – Either the smart appliance will communicate using a wireless medium or through the power lines. In either case, careful thought will be needed in separating the signal from the noise.

Diagnostics – One of the goals of the Smart Appliance initiative is to provide users with information about the health of the appliance. If sensors are to be placed on the appliance to monitor vibration, pressure, or current, it will be important to separate out useful information from these signals from noise introduced by the input power or through the air. Once again, an EMI filter may be a necessity.

Chaos Factor – When several Smart Appliances are brought into proximity with each other, their high frequency communication media will interact with each other. Without careful limits on EMI, considerable chaos could take place.

Whether for export market, or for the domestic Smart Appliance market, an integrated EMI filter and Control

makes sense. Understanding of high frequency electromagnetic noise will be a necessity for appliance designers of the today's new appliances. It has been shown several times that in the design of a motor control, that appliance designers need to trade off between high performance and low EMI levels.

BIBLIOGRAPHY

1. "Motor Comparison Chart" EDN Magazine, Pages 97-99, 1978
2. "Low Cost Universal Motor Phase Angle Drive System" Motorola Application Note AN1662, Revision 1, Ivan Skalka.
3. "Low Cost 3-Phase AC Motor Control System Based on MC68HC908MR24", Motorola Application Note AN1664, Rafim Visinka.
4. "Designing for EMC Compliance" AMCE 2001, Nissen Isakov, October 2001.
5. "A System Approach to Integrated Appliance Controls" AMCE 2001, Carl J. Dister, October 2001.
6. "EMC of Variable Speed Drives" Dr. Colin Hargis, EMC Compliance Journal and European Compliance Club, Jan 2002.
7. "Appliance Design for Reduced EMI/RFI Emissions", Jan 1995, IATC, Carl J. Dister and Robert K. Wargo.
8. "Radio Frequency Interference of Electric Motors and Associated Controls" IEEE IAS Jan/Feb 1991

- Vol 27 No. 1, M.A. Jabbar, M. Azizur Rahman
9. "Inverter-Fed Motor Drive with EMI Suppression" US Patent #5,661,390, Tom Lipo and Erkuan Zhong, August 1997.
 10. "Low EMI Emissions Heat Sink Device" US Patent #6,167,949, Philip Langley and Douglas Boone, Hewlett-Packard, Jan 2001.
 11. "Driving the Future: Use of Electronically Driven Motors in Appliances to Grow" Appliance Manufacturer, Sept 2001, Thomas Kaporch.
 12. "X10 FAQ", Harrison Cooper, Jan 1995
 13. "Envisioning the Future of Bluetooth Enabled Domestic Appliances" AMCE 2001, Spencer Murrell, Fitch Worldwide, Oct 2001
 14. "Appliance Networking Technology", AMCE 2001, Guy-Anne Paquet, Bernardino Camba, Oct 2001
 15. "Using Temperatures, Voltage, and/or Speed Measurements to Improve Trending of Induction Motor RMS Currents in Process Control and Diagnostics", Carl J. Dister and Rich Schiferl, IEEE IAS October Meeting 1998

Figures and Tables

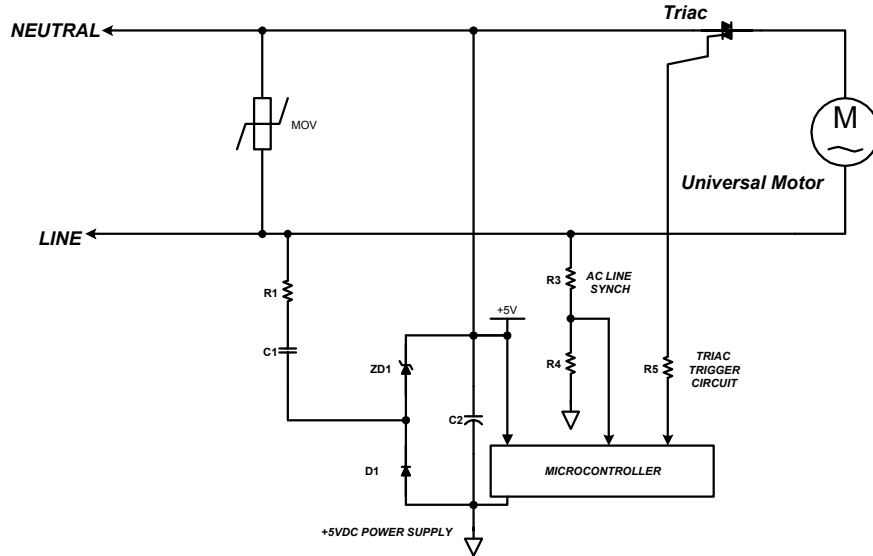

Figure 1: Typical Universal Motor Control

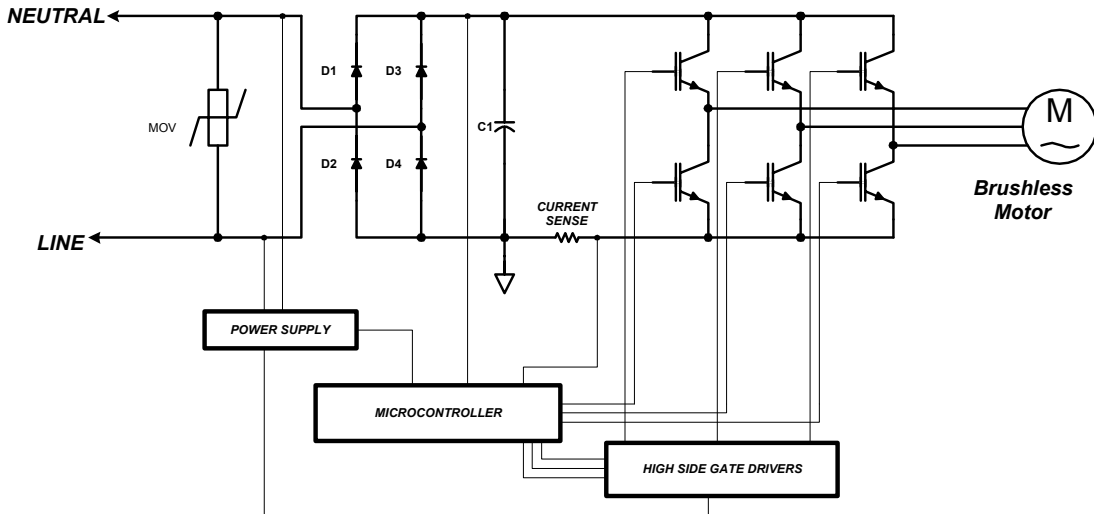

Figure 2: Typical Brushless Motor Control

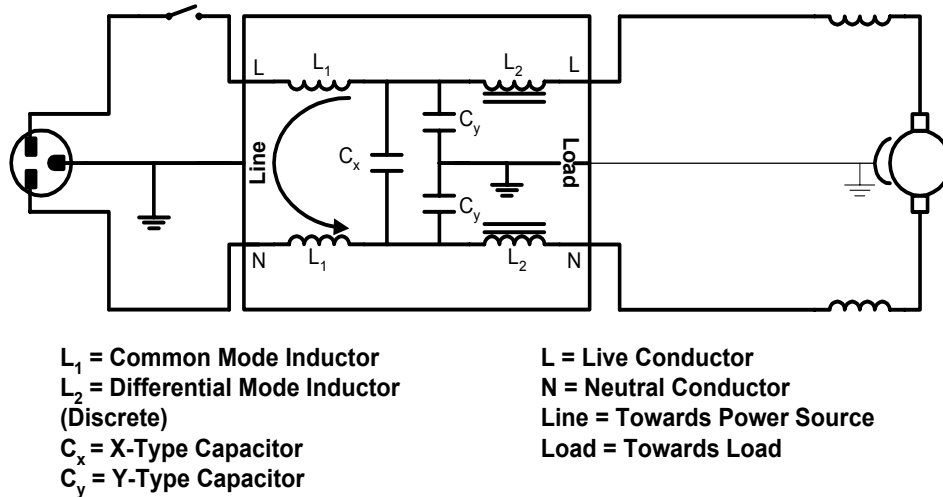

Figure 3: Typical EMI Filter

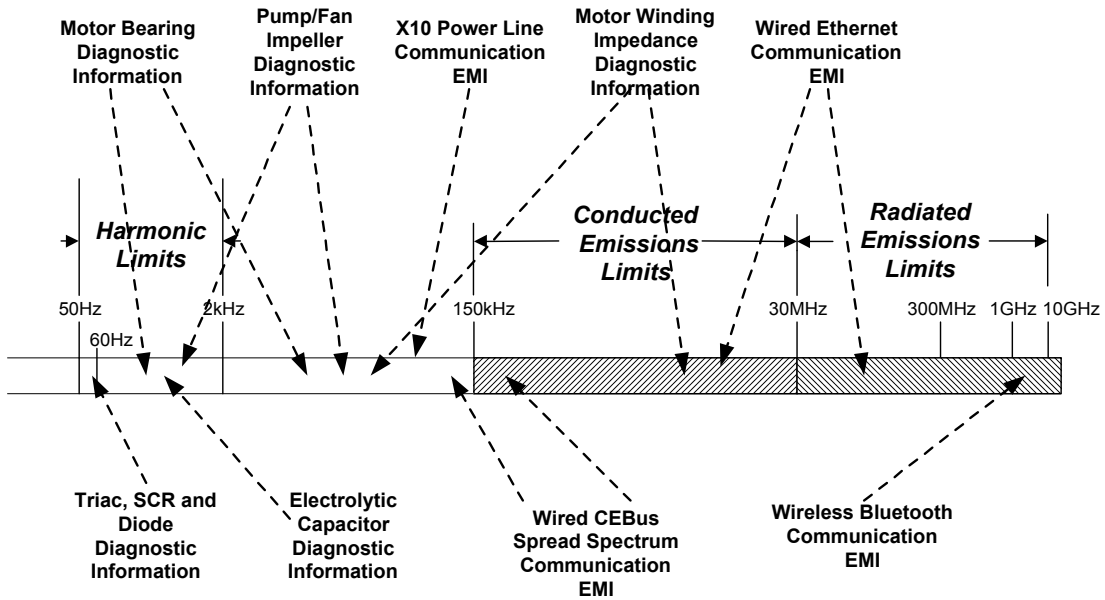

Figure 4: The Crowded EM Spectrum

Motor Type	Speed Control Options	Advantages/Disadvantages	Typical Applications
Universal	Triac - AC Line	Operates at high speeds. Can run off of AC line directly. Good low speed torque. High acoustic noise, low efficiency, brush EMI noise, and brush life are strong disadvantages	Mixers, Vacuum Cleaners, Power Tools
PM Brush	PWM Mosfet, SCR, or Battery	Operates at high speeds. Can operate from a battery supply. Better efficiency than Universal. Compact size. Brush EMI noise and life a disadvantage	Battery Operated Tools and Devices. Compact
Shaded Pole	Triac –AC Line	High reliability (no capacitors or brushes.) Inexpensive to produce. Difficult to operate at high speeds. Low operating efficiency.	HVAC fans/blowers.
Squirrel Cage	Mosfet (low voltage) IGBT (high voltage)	High reliability (no brushes.) Smooth torque. High efficiency. Lower speed operation.	Mixers / Pumps
PM Brushless	Mosfet (low voltage) IGBT (high voltage)	Excellent efficiency. Long motor life/reliability. Lower reliability control on AC power. Higher cost motor. Usually requires position sensor	High performance machine tools. High end washers
Switched Reluctance	Mosfet (low voltage) IGBT (high voltage)	Similar advantages to PM Brushless. More reliable rotor allows higher speed and higher temperature operation. Operates at high efficiency over a wide speed range. High torque ripple. Usually requires position sensor.	High speed tools. Washing machines. Pumps

Table 1 – Comparison of Motor Controllers